

Electric Cooktops

User Guide

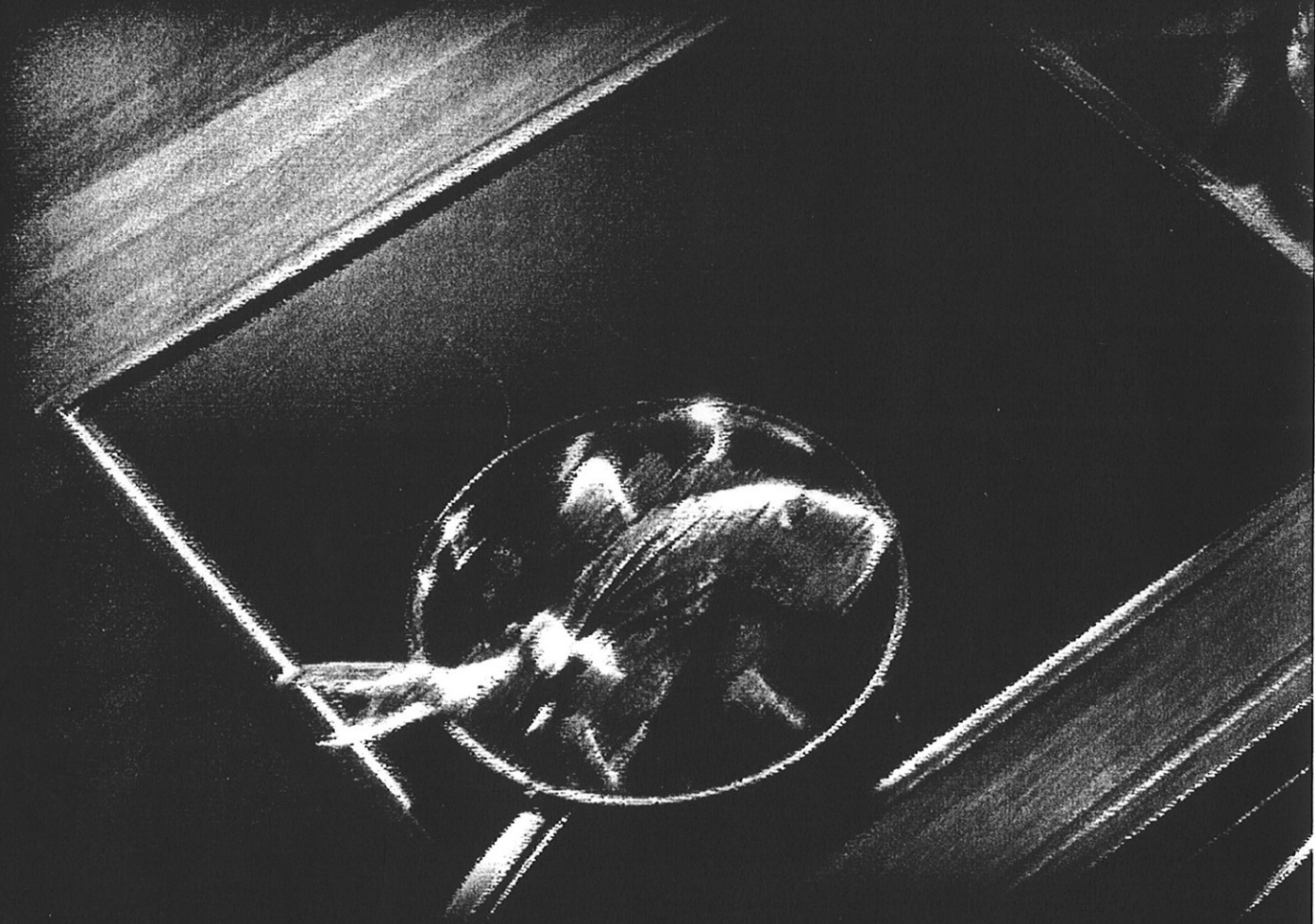

 **Electrolux**

Ceramic Cooktop Installation Instructions

Before installing the cooktop, read these points carefully.

Damage resulting from incorrect installation **WILL NOT** be covered by warranty.

It is the responsibility of the installer to make sure that:

- The cabinet is constructed correctly.
- The cooktop is installed according to the specifications in this leaflet.

Electrical Connection

- The cooktop **MUST** be installed by a qualified electrician.
- Electrical connection is 230-240 volts AC50Hz
- Check the electrical loading for the cooktop on the back page.
- The cooktop requires a means of all-pole disconnection incorporated into the fixed wiring. This **MUST** have a disconnection gap of 3mm.
- The cooktop **MUST** be earthed. Any damage caused by failure to earth will not be covered by warranty.
- The cooktop **MUST** be installed according to the relevant wiring regulations:
 - Australia • must comply with SAA wiring regulations
 - New Zealand • must comply with NZ wiring regulations
- The separate control panel of model PHL564 is only to be connected to the heating unit supplied with the control panel, in order to avoid a possible hazard.

Preparing the Bench

- Choose where you want to place the cooktop.
- For separate control panel model decide whether to position the control panel on the right or left.
- Check the opening dimensions for the model and mark it out on the bench (refer to back page)
- A minimum gap of 30mm is needed under the cooktop.
- Make sure that nothing (e.g. a timber member) interferes with these space requirements.
- Cut the opening in the benchtop.
- Any walls around the cooktop are to be heat resistant up to 90°C, up to 150mm high. i.e. ceramic tiles.
- NOTE; The cooktop is designed for the glass to sit on top of the bench. The glass must not be recessed into the bench.

Barrier Installation

- If the base of the cooktop can be touched from inside a cupboard or drawer, a barrier **MUST** be installed to prevent contact.
- Make sure the material for the barrier is capable of sustained heat up to 70°C e.g. wood or metal. **DO NOT** use plastic or plastic coated wood.
- Make sure it is at least 50mm, and not more than 75mm, below the base of the cooktop.
- Make sure it has ventilation holes that are open to free air, and evenly spaced (see diagrams on back)
- Check the number of holes from this list:

Twenty Five holes	25mm diameter.
Fifteen holes	35mm diameter.
Six holes	50mm diameter.

2-HOTPLATE

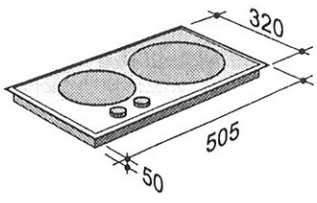
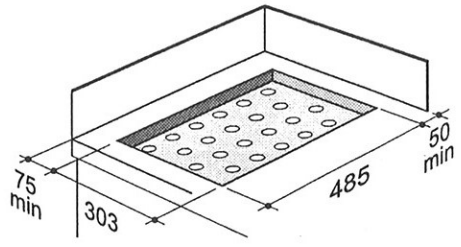
Model	KW Rating	Cooktop Dimensions	Cut-out Dimensions
PHL222	3.0 kw		

3 & 4-HOTPLATES

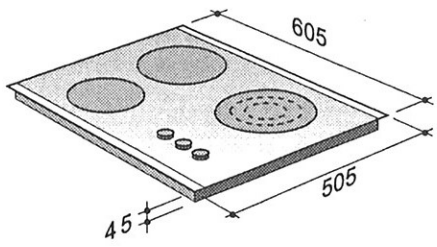
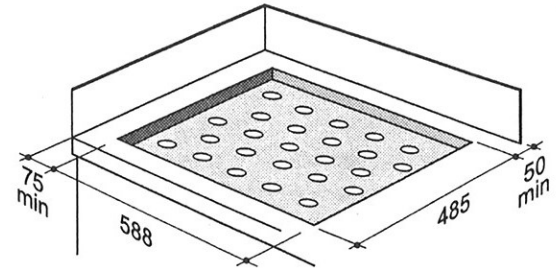
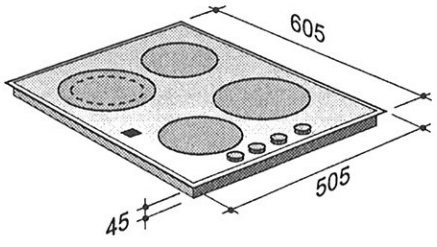
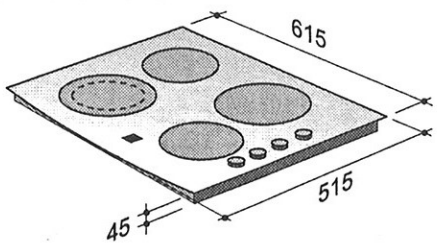
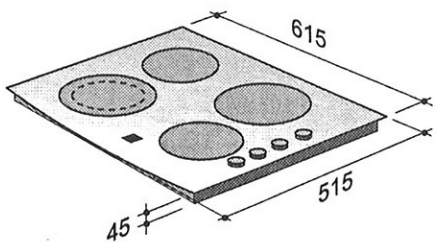
Model	KW Rating	Cooktop Dimensions	Cut-out Dimensions
EHC633 EHE633	5.2 kw		
3C401 64G985 64G988	6.0 kw		
PHL285 EHC643 EHE643	6.4 kw		
PHL284 PHL768	6.4 kw 6.5 kw		

SEPARATE CONTROLS

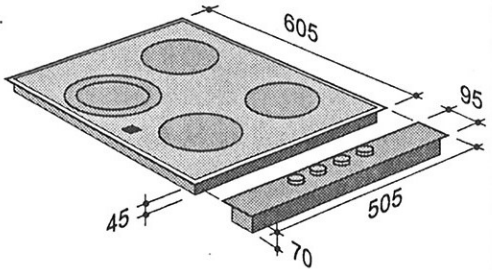
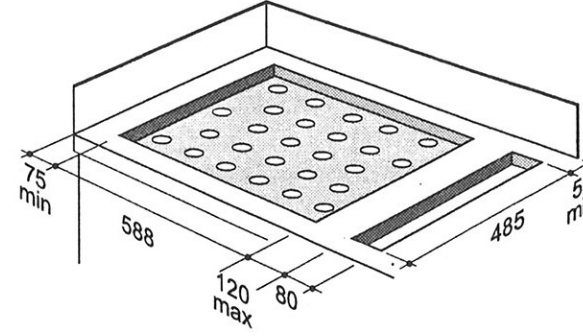
Model	KW Rating	Cooktop Dimensions	Cut-out Dimensions
PHL564	6.4 kw		

 **The Electrolux Group. The world's No.1 choice.**

The Electrolux Group is the world's largest producer of powered appliances for kitchen, cleaning and outdoor use. More than 55 million Electrolux Group products (such as refrigerators, cookers, washing machines, vacuum cleaners, chain saws and lawn mowers) are sold each year to a value of approx. US 14 billion in more than 150 countries around the world.

Using the Cooktop for the First Time

Before you use your cooktop for the first time, read these instructions carefully.

- Switch the element on for 5 to 10 minutes. This will get rid of.
 - material left from the manufacturing process.
 - odours.Some smoke may appear but this is normal and will soon disappear.
- When the ceramic surface is cooled, clean it with a non-abrasive liquid ceramic cooktop cleaner e.g. Mica cooktop cleaners and conditioners.
- **DO NOT** use the cooktops as a work surface as this may scratch the surface.
- **DO NOT** cut or chop food on the ceramic surface.

Cleaning Instructions

- Clean the cooktop regularly while it is still warm with a suitable non-abrasive liquid ceramic cooktop cleaner.
- Remove melted material **IMMEDIATELY** while the surface is still hot by:
 - using a razor blade scraper to remove material.
 - using a ceramic glass scraper.
 - rinsing and wiping dry with a clean cloth or paper towel.
- **DO NOT** leave food on ceramic surface as cooktop may become stained.
- **DO NOT** use abrasive or corrosive cleaners, scouring pads, steam cleaners, wire wool or oven cleaners.
- Be careful not to scratch the surface with bracelets or rings.

Troubleshooting

If you call for a service and there is nothing wrong with your cooktop, you will have to pay for the service call. You will have to pay even when the cooktop is under warranty. Before you call for service, check the points in these tables.

Problem	Possible Causes
Elements do not operate	<ul style="list-style-type: none">• Power supply is off• Power not turned on• Controls set incorrectly• Household fuse has blown - if fuse keeps blowing then call the Service Centre
Low Heat, slow cooking	<ul style="list-style-type: none">• Incorrect cooking utensils being used

Information, Service and Parts

Service

If you need information, service or replacement parts you need to quote

- The model number
- The serial number

These numbers are on the data plate which is on the bottom of the switch panel cover.

If you need more information, please contact the **Customer Care Centre**

Australia

On 1300 363 640

Open from 8.00 am till 5.00 pm

Monday to Friday (Eastern Standard Time).

New Zealand

Or 09 573 2384

Open from 8.00 am till 5.00 pm

Monday to Friday.

New Zealand Product Warranty

This appliance is warranted by Electrolux (NZ) Limited ("the Company") to be free from defects in material and workmanship for a period of 90 days from the date of purchase where the purchaser acquires that appliance for the purposes of a "business" as defined in the Consumers Guarantees Act 1993 ("Act"). In all other circumstances, this appliance is warranted by the Company to be free from defects in material and workmanship for a period of 2 years from the date of purchase. Any defect becoming apparent as a result of failure of material or workmanship during the warranty period will be rectified free of charge by the company or its service centre.

Conditions

- During the warranty period the company, or its service centre, will pay the cost of repairing or replacing all parts which are defective.
- The Consumer Guarantees Act 1993 does not apply if your appliance is acquired for the purposes of a "business" (as defined in that Act).
- The appliance must be installed and operated in accordance with the Company's instructions.
- It does not apply to normal wear and tear, or any service which is needed after an accident, negligence, alterations or misuse.
- It also does not apply to damage caused if your appliance has been dismantled, repaired or serviced by any person other than someone authorised by the Company
- It does not cover the cost of transport for service if you live outside the service area.
- This warranty is the only express warranty given by the Company.
- Nothing in this warranty is intended to limit the rights you may have under the Consumer Guarantees Act 1993, except to the extent permitted by that Act and all provisions of this warranty shall be read as modified to the extent necessary to give effect to that intention.

Electrolux (NZ) Limited

3 Niall Burgess Road, Mt Wellington, PO. Box 12-170, Penrose, Auckland, New Zealand. Ph (09) 573-2220

Product:..... Date of Purchase:.....
Model:..... Serial No.....
Purchaser's Name:..... Ltū ā
Full Postal Name:.....
Full Postal Address:.....
Retailer:.....
Address:.....

Please retain this Leaflet together with receipt or other proof of purchase when seeking service during the warranty period.

Service

For your nearest Authorised Service Centre look in the Yellow Pages under "Home Appliance - Servicing", "Washing Machine Repairs", "Refrigeration Servicing" or telephone 0800-10-66-10. This will put you in contact with your nearest Authorised Service Centre.

Authorised Electrolux (NZ) Ltd Spare Parts Stockists

Dunedin	South City Champion, 590 Hillside Road	(03) 455-5443	Wellington	Prime Distributors Limited, 68 Victoria Street Petone	(04) 586-2150
Christchurch	Prime Distributors Limited, 15 Talfourd Place R Redpath Limited, 55 Ferry Road	(03) 377-1009 (03) 379-0446	Auckland	Prime Distributors Limited, 8 Highbrook Drive, East Tamaki	(09) 273-3580

Australian Product Warranty

WARRANTY ON COOKING APPLIANCES

This appliance is warranted by the manufacturer, Electrolux Home Products Australia Pty Ltd (hereinafter called the Company"), which undertakes by this warranty for the first year after installation, the Company or its agent will pay the costs of repairing or replacing all parts the Company or its agent find defective. (But please note that you will have to pay for the cost of transport required, because of service located outside of areas serviced by the Company or its agent).

- This warranty applies only to Australia and does not cover any service consequent upon accident, alterations, misuse or fire.
- This warranty is conditional upon the appliance being used for personal, domestic or household purposes and installed and operated in accordance with the Company's Instructions.
- This warranty is the only express warranty given by the Company.
- The Company reserves the right to determine whether or not the fault is caused by faulty workmanship or material or that any part is defective.
- Where permitted by law, this warranty shall not apply to any loss suffered through or resulting from the non-operation or the ineffective operation of the Appliance or any part of the Appliance.
- Nothing in this warranty, however, shall be construed as limiting any rights you may have under the Trade Practices Act or any other Commonwealth or State Legislation

which gives you rights which cannot be modified or excluded by agreement.

To ensure that service either pursuant to the above undertaking or otherwise be readily available, Electrolux has established in all States authorised Service centres which are available to deal with service requirements. For further information, contact any of the Company's State Service centres.

Please complete data below for your future reference.

Model:..... Serial No:.....
Purchased from:..... Purchase Date:.....

Service and Warranty

Service

- Contact the people who know your cooktop best if you need service - during or after warranty.
- We are the national service organisation authorised by the manufacturer to service their products.
- Our technicians are factory trained.
- We offer guaranteed approved replacement parts and a full labour warranty as part of our service.

Please Phone

131349

For the cost of a local call
(Australia only)

Spares

For approved replacement parts for your appliance, your nearest stockist is only a phone call away!

Please phone

131350

For the cost of a local call
(Australia only)

 **The Electrolux Group. The world's No.1 choice.**

The Electrolux Group is the world's largest producer of powered appliances for kitchen, cleaning and outdoor use. More than 55 million Electrolux Group products (such as refrigerators, cookers, washing machines, vacuum cleaners, chain saws and lawn mowers) are sold each year to a value of approx. US 14 billion in more than 150 countries around the world.

Safety Instructions

It is important to use your cooktop safely. Check these safety points before using your cooktop.

- This appliance is not intended for use by young children or infirm persons without supervision.
- Put **ONLY** cookware on the cooking area.
- **DO NOT** cook directly on the ceramic surface as food will stick to the surface and will cause problems.
- If the ceramic cooktop cracks, **IMMEDIATELY** switch off the cooktop at the power supply.
- Keep anything which will melt away from the surface e.g. plastic, foil and sugar.
- **DO NOT** touch the cooktop while it is still hot.
- **DO NOT** stare at the Halogen Elements when cooking, (fitted on selected models).

Operating Instructions

The Features of your cooktop

- The heating elements are concealed under the smooth glass surface which has a pattern to show the location of the element.
- The elements are controlled by energy regulators (see diagram opposite).

Using the elements

- Choose the element you want to use.
- Set the control knob to the high setting so boiling point is reached quickly.
- Adjust the setting downwards until the desired heat setting is reached.

Dual circuit element

Some models have one element which has a dual circuit;

Circuit 1:	<ul style="list-style-type: none"> • allows the whole element to be heated 	<ul style="list-style-type: none"> • rotate the control knob to the right past halfway
Circuit 2:	<ul style="list-style-type: none"> • allows the central area only to be heated • saves energy when using smaller pans or when simmering gently 	<ul style="list-style-type: none"> • rotate the control knob to the right up to halfway

Warning Lights

- are located in the front of the cooktop under the ceramic top.
- show that the ceramic cooktop is still hot after the control is turned off.
- stay on until the cooktop has cooled down to below 60°C.

Choosing and Using Pots and Pans

- **DO NOT** operate an element without a cooking pot or pan on it.
- Use pots and pans with flat heavy bases. Pots and pans with uneven or thin bases will take longer to cook.
- **DO NOT** use pots or pans which overhang the elements more than 50mm. Oversized pots and pans can cause fine cracks on the cooktop (see diagram below).
- Check the base of pots and pans are level with a ruler.
- Check the bottoms of pots and pans are free from grit as this can scratch the ceramic surface.
- Cook with lids on pots and pans as this will save time and electricity.
- Always lift pots and pans from place to place on the ceramic surface. **DO NOT** slide the pots or pans as this may scratch the surface.
- **DO NOT** place steamy or wet utensils on the cooktop.

